

**Report Number: QIP-ASI204242**

**Audit Date :** 01 Apr.,2020

This report is issued by Focus Technology Co., Ltd. (Made-in-China.com) and the supervising inspectorate (SGS-CSTC Standards Technical Services Co., Ltd.) to confirm that:

**Company Name :** Yangzhou HePu Lighting Technology Co., Ltd.  
 扬州市禾普照明科技有限公司

**Showroom :** <http://hepu-solar-light.en.made-in-china.com>

**Address :** Guoji Industrial Zone, Gaoyou, Yangzhou, Jiangsu, China

**Product :** Street Light Pole, LED Street Light, Solar Street Light, Solar Panel, High Mast Light, LED Solar Street Light, Wind Turbine Solar Street Light, Garden Light, Solar Lithium Street Light, Solar Wind Hybrid Street Light

has been on site audited for the Following Scope of Activity

1. General Information
2. Foreign Trade Capacity
3. Product Research & Development Capacity
4. Management System and Product Certification
5. Production Capacity & Quality Control
6. Working Environment
7. Energy Saving and Emission Reduction
8. Photos



**General Comments:**

Yangzhou HePu Lighting Technology Co., Ltd. is a manufacturer with 61 employees; it was established in 200, located in Guoji Industrial Zone, Gaoyou, Yangzhou, Jiangsu, China. The buildings occupy an area of more than 8,000 square meters. Yangzhou HePu Lighting Technology Co., Ltd. has its own brand. They have passed ISO9001:2015 certification, ISO14001:2015 certification, ISO45001:2018 certification and obtained CCC certificate, China Certificate For Energy Conservation Product for its products for its products. Yangzhou HePu Lighting Technology Co., Ltd. has successful foreign trading experience in Europe, Southeast Asia, Mideast and Africa.



Sign for and on behalf of  
 SGS-CSTC Standards Technical Services Co., Ltd.



Unless otherwise agreed in writing, this document is issued by the Company under its General Conditions of Service accessible at <http://www.sgs.com/en/Terms-and-Conditions.aspx> Attention is drawn to the limitation of liability, indemnification and jurisdiction issues defined therein. Any holder of this document is advised that information contained hereon is solely limited to visual examination of the safely and readily accessible portions of the consignment and reflects the Company's findings at the time of its intervention only and within the limits of Client's instructions, if any. The Company's sole responsibility is to its Client and this document does not exonerate parties to a transaction from exercising all their rights and obligations under the transaction documents. Any unauthorized alteration, forgery or falsification of the content or appearance of this document is unlawful and offenders may be prosecuted to the fullest extent of the law.

Attention: To check the authenticity of testing /inspection report & certificate, please contact us at telephone: (86-755) 8307 1443, or email: [CN.Doccheck@sgs.com](mailto:CN.Doccheck@sgs.com) **Page No.: 1 of 22**

SGS-CSTC Standards Technical Services Co., Ltd.  
 Consumer and Producer

5/F, B-4 Building, Zijin (Baixia) Technology Incubation Special Park, No.1 Guanghua Road, Nanjing, China 210014 t (86-25) 87128385 f (86-25) 83407773 www.sgsgroup.com.cn  
 中国·南京·秦淮区光华路1号紫金白下创业特别社区4号楼B幢5楼 邮编: 210014 t (86-25) 87128385 f (86-25) 83407773 e as.cn@sgs.com

# SUPPLIER ASSESSMENT REPORT

Audited Company	Yangzhou HePu Lighting Technology Co., Ltd.
Audited Site:	Guoji Industrial Zone, Gaoyou, Yangzhou, Jiangsu, China

Consigner of Assessment	Made-in-China.com		
Audit Type	<input checked="" type="checkbox"/> Initial Audit <input type="checkbox"/> Re-audit		
Audit Date	01 Apr.,2020	Verify Report	<a href="http://www.sgs.com/ecv">www.sgs.com/ecv</a>
Auditor	Simon Gao	Reviewed by	Toby Han

## CONTENTS

- Part A: General Information**
  - Section 1: Company Overview
  - Section 2: Human Resources
- Part B: Foreign Trade Capacity**
  - Section 1: Export Overall Situation
  - Section 2: Export Business Capacity
  - Section 3: Supplier Management
  - Section 4: After-sales Service Capacity
- Part C: Product Research & Development Capacity**
  - Section 1: Product Research & Development Capacity
- Part D: Management System and Product Certification**
  - Section 1: Management System(s) and Product Certification
- Part E: Production Capacity & Quality Control**
  - Section 1: Production Capacity Section
  - Section 2: Production Process Control
- Part F: Financial Position**
  - Section 1: Financial Data
  - Section 2: Key Performance Indications
  - Section 3: Banking
  - Section 4: Product Insurance
- Part G: Working Environment**
  - Section 1: Working Environment
- Part H: Energy Saving and Emission Reduction**
  - Section 1: Environmental Management
  - Section 2: Water, Gas and Noise Control
- Part I: Industry Information**
  - Section 1: Industry Information
- Part J: Photos**
  - Section 1: Photos of Documents
  - Section 2: Photos of Company



Unless otherwise agreed in writing, this document is issued by the Company under its General Conditions of Service accessible at <http://www.sgs.com/en/Terms-and-Conditions.aspx>. Attention is drawn to the limitation of liability, indemnification and jurisdiction issues defined therein. Any holder of this document is advised that information contained hereon is solely limited to visual examination of the safely and readily accessible portions of the consignment and reflects the Company's findings at the time of its intervention only and within the limits of Client's instructions, if any. The Company's sole responsibility is to its Client and this document does not exonerate parties to a transaction from exercising all their rights and obligations under the transaction documents. Any unauthorized alteration, forgery or falsification of the content or appearance of this document is unlawful and offenders may be prosecuted to the fullest extent of the law.

Attention: To check the authenticity of testing/inspection report & certificate, please contact us at telephone: (86-755) 8307 1443, or email: [CN.Doccheck@sgs.com](mailto:CN.Doccheck@sgs.com)

## Part A: General Information

### Section 1: Company Overview

1.1 Legal Validity			
Does the company have a valid business license?	<input checked="" type="checkbox"/> Yes <input type="checkbox"/> No <input type="checkbox"/> Others	Registration Number	913210846967816686
Year of established	17 Nov.,2009	Valid Date	Long Valid
Registered address	Guoji Industrial Zone, Songqiao Town, Gaoyou City		
Actual address	Guoji Industrial Zone, Songqiao Town, Gaoyou, Yangzhou, Jiangsu, China		
Does the company in abnormal operation status list of industrial and commercial bureau?	No		
Registered capital	RMB 50,880,000		
Name of legal representative	Mr. Chunliang Cen		
Business scope	Lighting lamps and lanterns light, traffic lights, traffic signs stem traffic sign guardrail lights in electronic police rod solar street light LED streetlight scenery complementary lamp lithium electricity solar street light gantry courtyard landscape lamp insecticidal lamp Chinese knot project-light lamp festival lamp lithium electricity integration light tunnel light panels, industrial and mining lamp lighting and lighting equipment components lithium battery light fittings wire and cable processing and sales of solar photovoltaic power generation system research and development design and manufacturing, colloidal battery sales, city and road lighting engineering building lighting landscape lighting engineering Intelligent engineering design, construction and installation of municipal public engineering buildings; import and export business of all kinds of commodities and technologies (except those commodities and technologies that are restricted by the state or prohibited from import and export by the state); (business activities can only be carried out for those projects that are subject to approval by relevant departments according to law)		
1.2 Basic Information			
Contact person	Ms. Nina Xu		
Phone number	0086-18605210538	Fax number	Confidential
URL/Web address	<a href="http://www.hpstreetlight.com">http://www.hpstreetlight.com</a>		
Company type	<input type="checkbox"/> Manufacturer <input type="checkbox"/> Trading Company <input checked="" type="checkbox"/> Combined <input type="checkbox"/> Group Corporation		
Type of ownership	<input checked="" type="checkbox"/> Limited Company <input type="checkbox"/> Public Company <input type="checkbox"/> Foreign joint venture <input type="checkbox"/> State-Owned <input type="checkbox"/> Private Owner <input type="checkbox"/> Wholly foreign-owned enterprises		
Associated company	Confidential		
Products manufactured / sold scope	Street Light Pole, LED Street Light, Solar Street Light, Solar Panel, High Mast Light, LED Solar Street Light, Wind Turbine Solar Street Light, Garden Light, Solar Lithium Street Light, Solar Wind Hybrid Street Light		



Unless otherwise agreed in writing, this document is issued by the Company under its General Conditions of Service accessible at <http://www.sgs.com/en/Terms-and-Conditions.aspx>. Attention is drawn to the limitation of liability, indemnification and jurisdiction issues defined therein. Any holder of this document is advised that information contained hereon is solely limited to visual examination of the safely and readily accessible portions of the consignment and reflects the Company's findings at the time of its intervention only and within the limits of Client's instructions, if any. The Company's sole responsibility is to its Client and this document does not exonerate parties to a transaction from exercising all their rights and obligations under the transaction documents. Any unauthorized alteration, forgery or falsification of the content or appearance of this document is unlawful and offenders may be prosecuted to the fullest extent of the law.

Attention: To check the authenticity of testing/inspection report & certificate, please contact us at telephone: (86-755) 8307 1443, or email: [CN.Doccheck@sgs.com](mailto:CN.Doccheck@sgs.com)

Page No.: 3 of 22

5/F, B-4 Building, Zijin (Baixia) Technology Incubation Special Park, No.1 Guanghua Road, Nanjing, China 210014 t (86-25) 87128385 f (86-25) 83407773 www.sgsgroup.com.cn  
 中国·南京·秦淮区光华路1号紫金白下创业特别社区4号楼B幢5楼 邮编: 210014 t (86-25) 87128385 f (86-25) 83407773 e as.cn@sgs.com

### 1.3 Company Building Information

According to:

- Land certificate                       Real estate certificate  
 Lease agreement                       Observation Estimated on site

The company area 8,000 square meters  
 The land occupies 12,000 square meters.  
 The offices occupy 500 square meters.  
 The workshops occupy 6,500 square meters.



Unless otherwise agreed in writing, this document is issued by the Company under its General Conditions of Service accessible at <http://www.sgs.com/en/Terms-and-Conditions.aspx>. Attention is drawn to the limitation of liability, indemnification and jurisdiction issues defined therein. Any holder of this document is advised that information contained hereon is solely limited to visual examination of the safely and readily accessible portions of the consignment and reflects the Company's findings at the time of its intervention only and within the limits of Client's instructions, if any. The Company's sole responsibility is to its Client and this document does not exonerate parties to a transaction from exercising all their rights and obligations under the transaction documents. Any unauthorized alteration, forgery or falsification of the content or appearance of this document is unlawful and offenders may be prosecuted to the fullest extent of the law.

Attention: To check the authenticity of testing/inspection report & certificate, please contact us at telephone: (86-755) 8307 1443, or email: [CN.Doccheck@sgs.com](mailto:CN.Doccheck@sgs.com)

Page No.: 4 of 22



**Section 2: Human Resources**

**2.1 Company Chart**

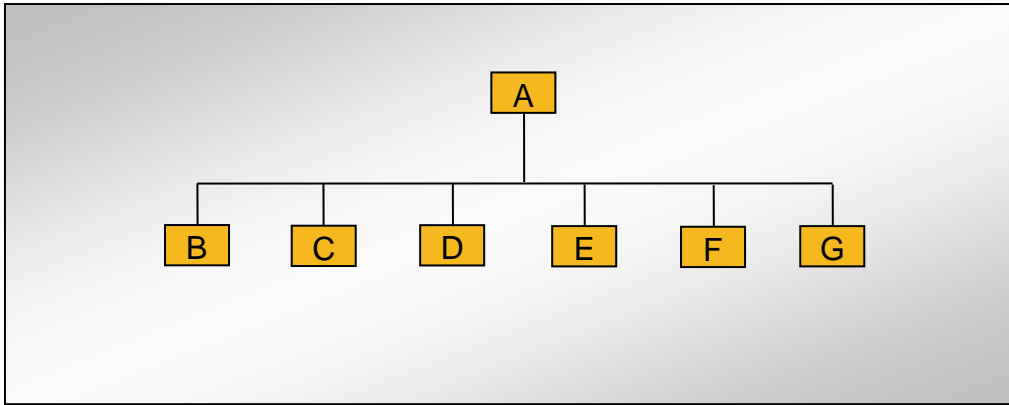

**2.2 Explanation of Code and Employee Details**

Code	Department	Number of employees
A	General Manager	1
B	Financial Dept.	2
C	Integrated Dept.	5
D	Technology Dept.	3
E	Sales Dept.	6
F	Quality Control Dept.	4
G	Production Dept.	40
<b>Number in total:</b>		61

**2.3 Key Staff**

Title	Full name	Education	Working experience for this trade / total experience
Confidential	Confidential	Confidential	Confidential



Unless otherwise agreed in writing, this document is issued by the Company under its General Conditions of Service accessible at <http://www.sgs.com/en/Terms-and-Conditions.aspx>. Attention is drawn to the limitation of liability, indemnification and jurisdiction issues defined therein. Any holder of this document is advised that information contained hereon is solely limited to visual examination of the safely and readily accessible portions of the consignment and reflects the Company's findings at the time of its intervention only and within the limits of Client's instructions, if any. The Company's sole responsibility is to its Client and this document does not exonerate parties to a transaction from exercising all their rights and obligations under the transaction documents. Any unauthorized alteration, forgery or falsification of the content or appearance of this document is unlawful and offenders may be prosecuted to the fullest extent of the law.

Attention: To check the authenticity of testing/inspection report & certificate, please contact us at telephone: (86-755) 8307 1443, or email: CN.Doccheck@sgs.com

**Page No.: 5 of 22**

S/F, B-4 Building, Zijin (Baixia) Technology Incubation Special Park, No.1 Guanghua Road, Nanjing, China 210014 t (86-25) 87128385 f (86-25) 83407773 www.sgsgroup.com.cn  
 中国·南京·秦淮区光华路1号紫金白下创业特别社区4号楼B幢5楼 邮编: 210014 t (86-25) 87128385 f (86-25) 83407773 e as.cn@sgs.com

## Part B: Foreign Trade Capacity

### Section 1: Export Overall Situation

1.1 Export Overall Situation	
Does the company have a valid Import and Export license?	<input checked="" type="checkbox"/> Yes <input type="checkbox"/> No
The import and export enterprise code.	913210846967816686
The number of foreign trading staff with relevant trading experience.	<input type="checkbox"/> within 1 year staff <input checked="" type="checkbox"/> 1-5 years 2 staffs <input checked="" type="checkbox"/> 6-10 years 2 staffs <input checked="" type="checkbox"/> over 10 years 1 staff Total 5 staffs
The language freely used by foreign trade staff	<input checked="" type="checkbox"/> English <input type="checkbox"/> others:
Annual revenue of previous year	Confidential
Annual export revenue of previous year	Confidential
Estimated export revenue for this year.	Confidential
Overseas agent / branch	<input type="checkbox"/> Yes <input checked="" type="checkbox"/> No
Nearest port	Shanghai Port
Acceptable quotation terms	<input checked="" type="checkbox"/> FOB <input checked="" type="checkbox"/> CIF <input checked="" type="checkbox"/> CFR Other:EXW
Acceptable payment terms	<input checked="" type="checkbox"/> LC <input checked="" type="checkbox"/> T/T <input type="checkbox"/> D/P <input checked="" type="checkbox"/> PayPal <input checked="" type="checkbox"/> Western Union <input checked="" type="checkbox"/> Small-amount payment
Average lead time (Peak Season)	<input type="checkbox"/> within 15 workday <input checked="" type="checkbox"/> one month <input type="checkbox"/> 2-3 months <input type="checkbox"/> 4-6 months <input type="checkbox"/> 6-12 months <input type="checkbox"/> more time
Average lead time (Off Season)	<input checked="" type="checkbox"/> within 15 workday <input type="checkbox"/> one month <input type="checkbox"/> 2-3 months <input type="checkbox"/> 4-6 months <input type="checkbox"/> 6-12 months <input type="checkbox"/> more time

### Section 2: Export Business Capacity

2.1 Market Distribution (please list top three areas)		
Market	Main Product	Main client
<input type="checkbox"/> North America		
<input type="checkbox"/> South America		
<input checked="" type="checkbox"/> Europe	Street Light Pole, LED Street Light, Solar Street Light, Solar Panel, High Mast Light, LED Solar Street Light, Wind Turbine Solar Street Light, Garden Light, Solar Lithium Street Light, Solar Wind Hybrid Street Light	Confidential
<input checked="" type="checkbox"/> Southeast Asia/ Mideast	Street Light Pole, LED Street Light, Solar Street Light, Solar Panel, High Mast Light, LED Solar Street Light, Wind Turbine Solar Street Light, Garden Light, Solar Lithium Street Light, Solar Wind Hybrid Street Light	Confidential
<input checked="" type="checkbox"/> Africa	Street Light Pole, LED Street Light, Solar Street Light, Solar Panel, High Mast Light, LED Solar Street Light, Wind Turbine Solar Street Light, Garden Light, Solar Lithium Street Light, Solar Wind Hybrid Street Light	Confidential
<input type="checkbox"/> East Asia (Japan/ South Korea)		
<input type="checkbox"/> Australia		
<input checked="" type="checkbox"/> Domestic	Street Light Pole, LED Street Light, Solar Street Light, Solar Panel, High Mast Light, LED Solar Street Light, Wind Turbine Solar Street Light, Garden Light, Solar Lithium Street Light, Solar Wind Hybrid Street Light	Confidential
<input type="checkbox"/> Others		



Unless otherwise agreed in writing, this document is issued by the Company under its General Conditions of Service accessible at <http://www.sgs.com/en/Terms-and-Conditions.aspx> Attention is drawn to the limitation of liability, indemnification and jurisdiction issues defined therein. Any holder of this document is advised that information contained hereon is solely limited to visual examination of the safely and readily accessible portions of the consignment and reflects the Company's findings at the time of its intervention only and within the limits of Client's instructions, if any. The Company's sole responsibility is to its Client and this document does not exonerate parties to a transaction from exercising all their rights and obligations under the transaction documents. Any unauthorized alteration, forgery or falsification of the content or appearance of this document is unlawful and offenders may be prosecuted to the fullest extent of the law.

Attention: To check the authenticity of testing/inspection report & certificate, please contact us at telephone: (86-755) 8307 1443, or email: [CN.Doccheck@sgs.com](mailto:CN.Doccheck@sgs.com)

### Section 3: Supplier Management

3.1 Supplier Management		
Item	Content	Observations /Comments
1	Does the company establish and implement an effective suppliers' assessment procedure?	<input checked="" type="checkbox"/> Have the written procedures and followed records <input type="checkbox"/> Have the written procedures but no records <input type="checkbox"/> Have relevant records without written procedure <input type="checkbox"/> No written procedures or followed records <input type="checkbox"/> Other
2	Does the company have an updated list of approved suppliers?	<input checked="" type="checkbox"/> The approved suppliers list was updated in <u>2020</u> <input type="checkbox"/> Have the written suppliers without approved signature or date. <input type="checkbox"/> Provided some suppliers names <input type="checkbox"/> No approved suppliers list <input type="checkbox"/> Other

### Section 4: After-sales Service Capacity

4.1 After-sales Service Capacity		
Item	Content	Observations /Comments
1	Is there a procedure to conduct random product inspection after final packaging in place?	<input type="checkbox"/> Have clear standards and written inspection records <input type="checkbox"/> No written standards but had inspection reports <input type="checkbox"/> Have the procedures but no inspection records <input checked="" type="checkbox"/> It's not necessary to carry out the inspection <input type="checkbox"/> Other
2	Is there a clear procedure for handling customer complaints?	<input checked="" type="checkbox"/> Has the clear procedure and followed records <input type="checkbox"/> Has the procedure but no written records. <input type="checkbox"/> No written procedures or records. <input type="checkbox"/> Other
3	Can the finished/packaged product be traced by lot identification to the appropriate raw materials test reports?	<input checked="" type="checkbox"/> Have the procedures to trace the raw materials. <input checked="" type="checkbox"/> Can trace main materials <input checked="" type="checkbox"/> Can trace production date. <input type="checkbox"/> Can't trace products <input type="checkbox"/> Other
4	Are corrective & preventive actions mechanism established and implemented effectively (including the suppliers/ sub-contractors control, incoming inspection, process control, final inspection and customer complaint)?	<input checked="" type="checkbox"/> Has the clear procedure and followed records <input type="checkbox"/> Has the procedure but no written records. <input type="checkbox"/> No written procedures or records. <input type="checkbox"/> Other



Unless otherwise agreed in writing, this document is issued by the Company under its General Conditions of Service accessible at <http://www.sgs.com/en/Terms-and-Conditions.aspx> Attention is drawn to the limitation of liability, indemnification and jurisdiction issues defined therein. Any holder of this document is advised that information contained hereon is solely limited to visual examination of the safely and readily accessible portions of the consignment and reflects the Company's findings at the time of its intervention only and within the limits of Client's instructions, if any. The Company's sole responsibility is to its Client and this document does not exonerate parties to a transaction from exercising all their rights and obligations under the transaction documents. Any unauthorized alteration, forgery or falsification of the content or appearance of this document is unlawful and offenders may be prosecuted to the fullest extent of the law.

Attention: To check the authenticity of testing/inspection report & certificate, please contact us at telephone: (86-755) 8307 1443, or email: [CN.Doccheck@sgs.com](mailto:CN.Doccheck@sgs.com)

## Part C: Product Research & Development Capacity

1.1 Product Research & Development Capacity	
The amount of R&D and relevant working experience.	<input type="checkbox"/> within 1 year staff <input type="checkbox"/> 1-5 years staff <input checked="" type="checkbox"/> 6-10 years 1 staff <input checked="" type="checkbox"/> over 10 years 2 staffs Total 3 engineers
What is the main job responsibility for R&D engineers?	Technology engineers were responsible for confirming customer's request, designing new products and providing technical support for production and after-sales service.
Is there any relevant design input, output, review, verification and validation documentation available for auditor to review?	YES
Is there any special software or instrument used by the R&D staffs during the design process of new products? If yes, please list the main software or instrument.	YES Software: AutoCAD, Solidworks, etc.
Does the company have an effective design change control procedure in place?	YES
Please list the patent certificates and qualification license.	Patent certificates: 201820007452.6; 201330416317.X, etc.



Unless otherwise agreed in writing, this document is issued by the Company under its General Conditions of Service accessible at <http://www.sgs.com/en/Terms-and-Conditions.aspx> Attention is drawn to the limitation of liability, indemnification and jurisdiction issues defined therein. Any holder of this document is advised that information contained hereon is solely limited to visual examination of the safely and readily accessible portions of the consignment and reflects the Company's findings at the time of its intervention only and within the limits of Client's instructions, if any. The Company's sole responsibility is to its Client and this document does not exonerate parties to a transaction from exercising all their rights and obligations under the transaction documents. Any unauthorized alteration, forgery or falsification of the content or appearance of this document is unlawful and offenders may be prosecuted to the fullest extent of the law.

Attention: To check the authenticity of testing/inspection report & certificate, please contact us at telephone: (86-755) 8307 1443, or email: [CN.Doccheck@sgs.com](mailto:CN.Doccheck@sgs.com)

Page No.: 8 of 22

SGS-CSI Standards Technical Services Co., Ltd.  
Consumer and Retailer Technical Services

5/F, B-4 Building, Zijin (Baixia) Technology Incubation Special Park, No.1 Guanghua Road, Nanjing, China 210014 t (86-25) 87128385 f (86-25) 83407773 www.sgsgroup.com.cn  
中国·南京·秦淮区光华路1号紫金白下创业特别社区4号楼B幢5楼 邮编: 210014 t (86-25) 87128385 f (86-25) 83407773 e as.cn@sgs.com



## Part D: Management System and Product Certification

### 1.1 Management System and Product Certification

Management system certification

- ISO9001:2015 certificate  
 Certificate Name:ISO9001:2015 certificate  
 NO.: 288SCC19Q-HPZM001973M  
 Issued by: Shanghai Center Certification Co., Ltd.  
 Issued Date: 24 Oct.,2019  
 Valid Until: 23 Oct.,2022  
 Scope: Sales of lamp pole, lamp, solar panel, high polo lamp, gel battery and lithium battery
  
- ISO14001:2015 certificate  
 Certificate Name:ISO14001:2015 certificate  
 NO.: 288SCC19E-HPZM000897M  
 Issued by: Shanghai Center Certification Co., Ltd.  
 Issued Date: 24 Oct.,2019  
 Valid Until: 23 Oct.,2022  
 Scope: Sales of lamp pole, lamp, solar panel, high pole lamp, gel battery and lithium battery and related Environmental management activities of involved sites
  
- OHSAS18001:2007 certificate  
 Certificate Name: OHSAS18001:2007 certificate  
 NO.: 288SCC19S-HPZM000732M  
 Issued by: Shanghai Center Certification Co., Ltd.  
 Issued Date: 23 Oct.,2019  
 Valid Until: 24 Oct.,2022  
 Scope: Sales of lamp pole, lamp, solar panel, high pole lamp, gel battery and lithium battery and related Occupational health and safety management activities of involved sites



Unless otherwise agreed in writing, this document is issued by the Company under its General Conditions of Service accessible at <http://www.sgs.com/en/Terms-and-Conditions.aspx> Attention is drawn to the limitation of liability, indemnification and jurisdiction issues defined therein. Any holder of this document is advised that information contained hereon is solely limited to visual examination of the safely and readily accessible portions of the consignment and reflects the Company's findings at the time of its intervention only and within the limits of Client's instructions, if any. The Company's sole responsibility is to its Client and this document does not exonerate parties to a transaction from exercising all their rights and obligations under the transaction documents. Any unauthorized alteration, forgery or falsification of the content or appearance of this document is unlawful and offenders may be prosecuted to the fullest extent of the law.

Attention: To check the authenticity of testing/inspection report & certificate, please contact us at telephone: (86-755) 8307 1443, or email: CN.Doccheck@sgs.com

<p>Product certification</p>	<p><input type="checkbox"/> CE</p> <p><input type="checkbox"/> UL</p> <p><input checked="" type="checkbox"/> CCC          Certificate Name:CCC NO.: 2018011001114732          Product Name: Fixed Luminaire For Incandescent Lamp          Model: CPD-001          Standard: GB7000.1-2015;GB7000.201-2008          Issued by: China Quality Certification Centre          Issue Date: 17 Sep.,2018</p> <p><input type="checkbox"/> RoHS</p> <p><input type="checkbox"/> FCC</p> <p><input checked="" type="checkbox"/> Others          Certificate Name:China Certificate for Energy Conservation Product          NO.: CQC18701210922          Product Name: Luminaire For Road and Street Lighting          Model: HPLED150 150W          Standard: CQC3127-2016          Issued by: China Quality Certification Centre          Issue Date: 02 Jan.,2019</p> <p><input type="checkbox"/> NIL</p>
<p>Test reports for raw materials</p>	<p><input type="checkbox"/> RoHS</p> <p><input type="checkbox"/> Reach</p> <p><input type="checkbox"/> Others</p> <p><input checked="" type="checkbox"/> NIL</p>



Unless otherwise agreed in writing, this document is issued by the Company under its General Conditions of Service accessible at <http://www.sgs.com/en/Terms-and-Conditions.aspx> Attention is drawn to the limitation of liability, indemnification and jurisdiction issues defined therein. Any holder of this document is advised that information contained hereon is solely limited to visual examination of the safely and readily accessible portions of the consignment and reflects the Company's findings at the time of its intervention only and within the limits of Client's instructions, if any. The Company's sole responsibility is to its Client and this document does not exonerate parties to a transaction from exercising all their rights and obligations under the transaction documents. Any unauthorized alteration, forgery or falsification of the content or appearance of this document is unlawful and offenders may be prosecuted to the fullest extent of the law.

Attention: To check the authenticity of testing (inspection report & certificate, please contact us at telephone: (86-755) 8307 1443, or email: [CN.Doccheck@sgs.com](mailto:CN.Doccheck@sgs.com)

## Part E: Production Capacity & Quality Control

### Section 1: Production Capacity

#### 1.1 Production Workflow Chart

Production Workflow Chart Of Street Light and Pole

	→		→	
Casting		Housing Coating		Assembly
	→		→	
Welding		Light Pole Coating		Assembly and Packing

Production Workflow Chart Of Solar Panel

	→		→	
Chip Testing		Chip Slitting		Automatic Welding
	→		→	
Laminating		Assembly		Function Test and Packing

Production Workflow Chart Of Lithium Battery and LED Light

	→		→	
Battery Welding		Assembly and Function Test		Aging



Unless otherwise agreed in writing, this document is issued by the Company under its General Conditions of Service accessible at <http://www.sgs.com/en/Terms-and-Conditions.aspx> Attention is drawn to the limitation of liability, indemnification and jurisdiction issues defined therein. Any holder of this document is advised that information contained hereon is solely limited to visual examination of the safely and readily accessible portions of the consignment and reflects the Company's findings at the time of its intervention only and within the limits of Client's instructions, if any. The Company's sole responsibility is to its Client and this document does not exonerate parties to a transaction from exercising all their rights and obligations under the transaction documents. Any unauthorized alteration, forgery or falsification of the content or appearance of this document is unlawful and offenders may be prosecuted to the fullest extent of the law.

Attention: To check the authenticity of testing/inspection report & certificate, please contact us at telephone: (86-755) 8307 1443, or email: [CN.Doccheck@sgs.com](mailto:CN.Doccheck@sgs.com)



Page No.: 11 of 22

SGS-CSI Standards Technical Services Co., Ltd.  
Consumer and Manufacturer





5/F, B-4 Building, Zijin (Baixia) Technology Incubation Special Park, No.1 Guanghua Road, Nanjing, China 210014 t (86-25) 87128385 f (86-25) 83407773 www.sgsgroup.com.cn  
中国·南京·秦淮区光华路1号紫金白下创业特别社区4号楼B幢5楼 邮编: 210014 t (86-25) 87128385 f (86-25) 83407773 e as.cn@sgs.com



**1.2 Products Situation (Top three Product Categories)**

Product	Price range	Min. order quantity	Top monthly output	Average monthly output	Total in 2019
 Street Light	Confidential	Confidential	Confidential	Confidential	Confidential
 Solar Panel	Confidential	Confidential	Confidential	Confidential	Confidential
 LED Light	Confidential	Confidential	Confidential	Confidential	Confidential

**1.3 Main Facilities**



Picture	Facility name	Brand or Country/Region of origin	Target Value/machine*day	Quantity
	Coating line	China	Confidential	2
	Casting machine	China	Confidential	3
	Chip slitting machine	China	Confidential	1
	Chip test machine	China	Confidential	1
	Chip welding machine	China	Confidential	1



Unless otherwise agreed in writing, this document is issued by the Company under its General Conditions of Service accessible at <http://www.sgs.com/en/Terms-and-Conditions.aspx>. Attention is drawn to the limitation of liability, indemnification and jurisdiction issues defined therein. Any holder of this document is advised that information contained hereon is solely limited to visual examination of the safely and readily accessible portions of the consignment and reflects the Company's findings at the time of its intervention only and within the limits of Client's instructions, if any. The Company's sole responsibility is to its Client and this document does not exonerate parties to a transaction from exercising all their rights and obligations under the transaction documents. Any unauthorized alteration, forgery or falsification of the content or appearance of this document is unlawful and offenders may be prosecuted to the fullest extent of the law.

Attention: To check the authenticity of testing/inspection report & certificate, please contact us at telephone: (86-755) 8307 1443, or email: [CN.Doccheck@sgs.com](mailto:CN.Doccheck@sgs.com)



	Laminating machine	China	Confidential	1
	Solar panel test machine	China	Confidential	1
	Frame assembly machine	China	Confidential	1
	Battery cell welding machine	China	Confidential	1
	Battery cell sorting machine	China	Confidential	1
	Assembly line	China	Confidential	4
	Aging line	China	Confidential	1



Unless otherwise agreed in writing, this document is issued by the Company under its General Conditions of Service accessible at <http://www.sgs.com/en/Terms-and-Conditions.aspx>. Attention is drawn to the limitation of liability, indemnification and jurisdiction issues defined therein. Any holder of this document is advised that information contained hereon is solely limited to visual examination of the safely and readily accessible portions of the consignment and reflects the Company's findings at the time of its intervention only and within the limits of Client's instructions, if any. The Company's sole responsibility is to its Client and this document does not exonerate parties to a transaction from exercising all their rights and obligations under the transaction documents. Any unauthorized alteration, forgery or falsification of the content or appearance of this document is unlawful and offenders may be prosecuted to the fullest extent of the law.

Attention: To check the authenticity of testing/inspection report & certificate, please contact us at telephone: (86-755) 8307 1443, or email: [CN.Doccheck@sgs.com](mailto:CN.Doccheck@sgs.com)

## Section 2: Production Process Control

2.1 Production Process Control		
Item	Content	Observations /Comments
1	Product R&D capacity	<input checked="" type="checkbox"/> Own brand <input checked="" type="checkbox"/> ODM <input checked="" type="checkbox"/> OEM
2	Are the environmental conditions, such as tidiness and cleanliness being controlled and suitable for the operation performed?	<input type="checkbox"/> Very tidy <input checked="" type="checkbox"/> Normal <input type="checkbox"/> Need to improve <input type="checkbox"/> Very poor
3	Are the necessary items /documents provided at appropriate location and under control?	<input checked="" type="checkbox"/> Work Instructions /procedures <input checked="" type="checkbox"/> Workmanship standard /acceptance <input type="checkbox"/> Golden sample /Approval sample <input type="checkbox"/> Product picture <input type="checkbox"/> Verbal by workshop director
4	Are written instructions available for incoming material inspections /testing? Is the relevant record maintained?	<input checked="" type="checkbox"/> Has instructions and uniformly followed <input type="checkbox"/> Has instruction but no written records <input type="checkbox"/> Materials checked by storage staff
5	Are written inspections /testing instructions available for finished products? Is the relevant record maintained?	<input checked="" type="checkbox"/> Have instructions and uniformly followed <input type="checkbox"/> Have instruction but no written records <input type="checkbox"/> Finished product checked by packing staff
6	What type of inspection is used for finished products?	<input type="checkbox"/> Random inspection <input type="checkbox"/> Visual inspection <input type="checkbox"/> Function inspection <input checked="" type="checkbox"/> 100% inspection <input checked="" type="checkbox"/> Visual inspection <input checked="" type="checkbox"/> Function inspection
7	Are non-conforming units clearly marked/ segregated to prevent accidental dispatch?	<input checked="" type="checkbox"/> Marked and segregated <input type="checkbox"/> Segregated but not marked clearly <input type="checkbox"/> Not found on site
8	How are the non-conforming units handled?	<input checked="" type="checkbox"/> Repaired and re-inspection <input checked="" type="checkbox"/> Picked out <input type="checkbox"/> Used under control <input type="checkbox"/> Others



Unless otherwise agreed in writing, this document is issued by the Company under its General Conditions of Service accessible at <http://www.sgs.com/en/Terms-and-Conditions.aspx> Attention is drawn to the limitation of liability, indemnification and jurisdiction issues defined therein. Any holder of this document is advised that information contained hereon is solely limited to visual examination of the safely and readily accessible portions of the consignment and reflects the Company's findings at the time of its intervention only and within the limits of Client's instructions, if any. The Company's sole responsibility is to its Client and this document does not exonerate parties to a transaction from exercising all their rights and obligations under the transaction documents. Any unauthorized alteration, forgery or falsification of the content or appearance of this document is unlawful and offenders may be prosecuted to the fullest extent of the law.

Attention: To check the authenticity of testing /inspection report & certificate, please contact us at telephone: (86-755) 8307 1443, or email: [CN.Doccheck@sgs.com](mailto:CN.Doccheck@sgs.com)

Page No.: 14 of 22

5/F, B-4 Building, Zijin (Baixia) Technology Incubation Special Park, No.1 Guanghua Road, Nanjing, China 210014 t (86-25) 87128385 f (86-25) 83407773 www.sgsgroup.com.cn  
 中国·南京·秦淮区光华路1号紫金白下创业特别社区4号楼B幢5楼 邮编: 210014 t (86-25) 87128385 f (86-25) 83407773 e as.cn@sgs.com

## Part G: Working Environment

### Section 1: Working Environment

1.1 Welfare Benefits		
Item	Content	Observations /Comments
1	Does the company have effective procedures to verify the age of staff at the time of recruitment?	<input checked="" type="checkbox"/> Has written procedure and keeps adequate age documents of workers <input type="checkbox"/> Has written procedure but doesn't follow records <input type="checkbox"/> Hasn't written procedure or follows records
2	Do all workers sign employment contracts with the factory?	<input checked="" type="checkbox"/> All workers sign employment contracts <input type="checkbox"/> Some workers sign employment contracts <input type="checkbox"/> Only management staff sign employment contracts <input type="checkbox"/> No staff sign employment contracts
3	Is statutory contribution required for all employees' social insurance (e.g. health insurance, unemployment insurance, accident insurance etc.) paid for by the enterprise?	<input type="checkbox"/> All workers have social insurance. <input checked="" type="checkbox"/> Some workers have social insurance <input checked="" type="checkbox"/> Only management staffs have social insurance <input type="checkbox"/> No staff have social insurance Remark: some workers had no social insurance due to personal willingness.
4	Does the company have a clear and effective policy on working hours, rest and vacations? If does, please list it.	<input checked="" type="checkbox"/> All staffs work kept to the policy <input type="checkbox"/> Most of the time it keeps to the policy except midseason. <input type="checkbox"/> Usually needs overtime. <input type="checkbox"/> No relevant records for working hours Describe the working hours: 8 hours per day, from Mon. to Fri.
5	Does the company pay extra remunerations for all overtime work?	<input checked="" type="checkbox"/> For all overtime work. <input type="checkbox"/> For official holidays <input type="checkbox"/> For official holidays except weekend. <input type="checkbox"/> No extra remunerations for overtime.
6	Does the company have dormitories for staff? If yes, please describe the condition.	<input type="checkbox"/> Provide dormitories for all staff <input type="checkbox"/> Provide dormitories for workers <input type="checkbox"/> Provide dormitories for management staff <input checked="" type="checkbox"/> No dormitories were provided. Describe the condition: N/A
1.2 Labor Protection		
Item	Content	Observations /Comments
1	Are there uniforms for all staff in company?	<input checked="" type="checkbox"/> Yes <input type="checkbox"/> No <input type="checkbox"/> Other
2	Is the emergency medical supplies enough and easily used in workshop?	<input checked="" type="checkbox"/> Yes <input type="checkbox"/> No <input type="checkbox"/> Other
3	Does the company arrange health and safety training for new workers?	<input checked="" type="checkbox"/> Yes <input type="checkbox"/> No <input type="checkbox"/> Other
4	Do the workers have the appropriate protective equipment during operation in workshop? Such as gloves, masks.	<input checked="" type="checkbox"/> Yes <input type="checkbox"/> No <input type="checkbox"/> Other
5	Is there training needed and carried out for fire protection?	<input checked="" type="checkbox"/> Yes <input type="checkbox"/> No <input type="checkbox"/> Other



Unless otherwise agreed in writing, this document is issued by the Company under its General Conditions of Service accessible at <http://www.sgs.com/en/Terms-and-Conditions.aspx> Attention is drawn to the limitation of liability, indemnification and jurisdiction issues defined therein. Any holder of this document is advised that information contained hereon is solely limited to visual examination of the safely and readily accessible portions of the consignment and reflects the Company's findings at the time of its intervention only and within the limits of Client's instructions, if any. The Company's sole responsibility is to its Client and this document does not exonerate parties to a transaction from exercising all their rights and obligations under the transaction documents. Any unauthorized alteration, forgery or falsification of the content or appearance of this document is unlawful and offenders may be prosecuted to the fullest extent of the law.

Attention: To check the authenticity of testing/inspection report & certificate, please contact us at telephone: (86-755) 8307 1443, or email: [CN.Doccheck@sgs.com](mailto:CN.Doccheck@sgs.com)

Page No.: 15 of 22

SGS-CSI Standards Technical Services Co., Ltd.  
Consumer and

5/F, B-4 Building, Zijin (Baixia) Technology Incubation Special Park, No.1 Guanghua Road, Nanjing, China 210014 t (86-25) 87128385 f (86-25) 83407773 www.sgsgroup.com.cn  
中国·南京·秦淮区光华路1号紫金白下创业特别社区4号楼B幢5楼 邮编: 210014 t (86-25) 87128385 f (86-25) 83407773 e as.cn@sgs.com

## Part H: Energy Saving and Emission Reduction

### Section 1: Environmental Management

1.1 Environmental Management		
Item	Content	Observations /Comments
1	Environmental Management System	<input checked="" type="checkbox"/> ISO 14001 Certificate <input type="checkbox"/> Cleaner production management <input type="checkbox"/> NIL
2	Environmental Impact Assessment	<input checked="" type="checkbox"/> The Report of Environmental impact assessment is approved by EPA Gaoyou City in 2016. <input type="checkbox"/> NIL
3	Check and Acceptance of Completed Constructive Projects	<input checked="" type="checkbox"/> The Report Completed Constructive Projects Inspection and Acceptance is approved. <input type="checkbox"/> NIL
4	"Three Simultaneity" for Environmental protection	<input type="checkbox"/> The Report of "Three Simultaneity" for Environmental protection Inspection and Acceptance is available. <input type="checkbox"/> NIL

### Section 2: Water, Gas and Noise Control

2.1 Water, Gas and Noise Control		
Item	Content	Observations /Comments
1	Water-intaking	<input type="checkbox"/> Water-intaking license <input type="checkbox"/> No water-intaking license <input checked="" type="checkbox"/> No water taken from natural water body
2	Waste water	<input type="checkbox"/> Water-draining license or contract <input type="checkbox"/> Having carried out waste water treatment before draining <input checked="" type="checkbox"/> Having carried out waste water monitoring and the result of which being within the standard limit <input type="checkbox"/> No detail activities were found
3	Emission to air	<input type="checkbox"/> Air pollutant emission license <input checked="" type="checkbox"/> Having carried out air pollutant emission monitoring and the result of which being within the standard limit <input type="checkbox"/> No detail activities were found to reduce emission to air
4	Classification and Recycling for solid waste	<input type="checkbox"/> Having applied trash classification recycling <input checked="" type="checkbox"/> Having special warehouse for hazardous waste <input type="checkbox"/> No detail activities were found
5	Noise	<input checked="" type="checkbox"/> The company carried out noise monitoring and the result of which being within the standard limit one time per year <input type="checkbox"/> No detail activities were found



Unless otherwise agreed in writing, this document is issued by the Company under its General Conditions of Service accessible at <http://www.sgs.com/en/Terms-and-Conditions.aspx> Attention is drawn to the limitation of liability, indemnification and jurisdiction issues defined therein. Any holder of this document is advised that information contained hereon is solely limited to visual examination of the safely and readily accessible portions of the consignment and reflects the Company's findings at the time of its intervention only and within the limits of Client's instructions, if any. The Company's sole responsibility is to its Client and this document does not exonerate parties to a transaction from exercising all their rights and obligations under the transaction documents. Any unauthorized alteration, forgery or falsification of the content or appearance of this document is unlawful and offenders may be prosecuted to the fullest extent of the law.

Attention: To check the authenticity of testing/inspection report & certificate, please contact us at telephone: (86-755) 8307 1443, or email: [CN.Doccheck@sgs.com](mailto:CN.Doccheck@sgs.com)

Page No.: 16 of 22

SGS-CSI Standards Technical Services Co., Ltd.  
Consumer and Technical Services

5/F, B-4 Building, Zijin (Baixia) Technology Incubation Special Park, No.1 Guanghua Road, Nanjing, China 210014 t (86-25) 87128385 f (86-25) 83407773 www.sgsgroup.com.cn  
中国·南京·秦淮区光华路1号紫金白下创业特别社区4号楼B幢5楼 邮编: 210014 t (86-25) 87128385 f (86-25) 83407773 e as.cn@sgs.com



## Part J: Photos

### Section 1: Photos of Documents

#### 1.1 Photos of Documents

Description: Business License



Description: Export License



Description: ISO9001 Certificate



Description: ISO14001 Certificate



Description: ISO45001 Certificate



Description: CCC Certificate



Unless otherwise agreed in writing, this document is issued by the Company under its General Conditions of Service accessible at <http://www.sgs.com/en/Terms-and-Conditions.aspx>. Attention is drawn to the limitation of liability, indemnification and jurisdiction issues defined therein. Any holder of this document is advised that information contained hereon is solely limited to visual examination of the safely and readily accessible portions of the consignment and reflects the Company's findings at the time of its intervention only and within the limits of Client's instructions, if any. The Company's sole responsibility is to its Client and this document does not exonerate parties to a transaction from exercising all their rights and obligations under the transaction documents. Any unauthorized alteration, forgery or falsification of the content or appearance of this document is unlawful and offenders may be prosecuted to the fullest extent of the law.

Attention: To check the authenticity of testing/inspection report & certificate, please contact us at telephone: (86-755) 8307 1443, or email: [CN.Doccheck@sgs.com](mailto:CN.Doccheck@sgs.com).  
 Page No.: 17 of 22  
 5/F, B-4 Building, Zijin (Baixia) Technology Incubation Special Park, No.1 Guanghua Road, Nanjing, China 210014 t (86-25) 87128385 f (86-25) 83407773 www.sgs.com.cn  
 中国·南京·秦淮区光华路1号紫金白下创业特别社区4号楼B幢5楼 邮编: 210014 t (86-25) 87128385 f (86-25) 83407773 e as.cn@sgs.com

**Description: China Certificate For Energy Conservation Product**



**Description: Trade Mark**



**Description: Utility Model Patent Certificate**



**Description: Design Patent Certificate**



**Description: National Work Safety Standardization Certificate**



**Description: China Famous Brand Certificate**



Unless otherwise agreed in writing, this document is issued by the Company under its General Conditions of Service accessible at <http://www.sgs.com/en/Terms-and-Conditions.aspx>. Attention is drawn to the limitation of liability, indemnification and jurisdiction issues defined therein. Any holder of this document is advised that information contained hereon is solely limited to visual examination of the safely and readily accessible portions of the consignment and reflects the Company's findings at the time of its intervention only and within the limits of Client's instructions, if any. The Company's sole responsibility is to its Client and this document does not exonerate parties to a transaction from exercising all their rights and obligations under the transaction documents. Any unauthorized alteration, forgery or falsification of the content or appearance of this document is unlawful and offenders may be prosecuted to the fullest extent of the law.

Attention: To check the authenticity of testing/inspection report & certificate, please contact us at telephone: (86-755) 8307 1443, or email: [CN.Doccheck@sgs.com](mailto:CN.Doccheck@sgs.com)

Page No.: 18 of 22

SIF, B-4 Building, Zijin (Baixia) Technology Incubation Special Park, No.1 Guanghua Road, Nanjing, China 210014 t (86-25) 87128385 f (86-25) 83407773 www.sgsgroup.com.cn  
 中国·南京·秦淮区光华路1号紫金白下创业特别社区4号楼B幢5楼 邮编: 210014 t (86-25) 87128385 f (86-25) 83407773 e as.cn@sgs.com



**Description: China Quality Credit Enterprise**



**Description: Excellent Supplier of Government Procurement Certificate**



**Description: Jiangsu Credit AAA Enterprise Certificate**

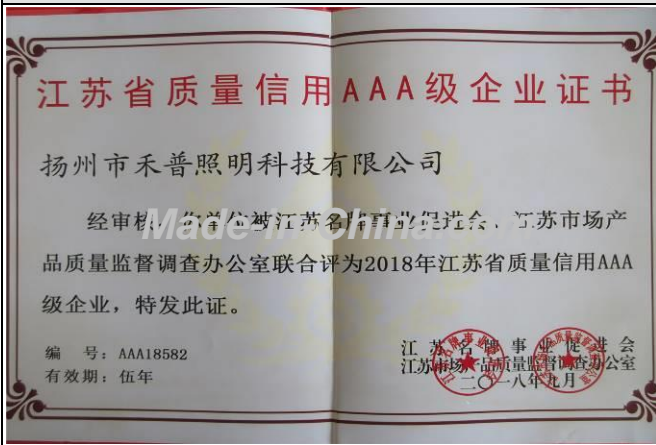

**Description: National 315 Credit Units**



Unless otherwise agreed in writing, this document is issued by the Company under its General Conditions of Service accessible at <http://www.sgs.com/en/Terms-and-Conditions.aspx>. Attention is drawn to the limitation of liability, indemnification and jurisdiction issues defined therein. Any holder of this document is advised that information contained hereon is solely limited to visual examination of the safely and readily accessible portions of the consignment and reflects the Company's findings at the time of its intervention only and within the limits of Client's instructions, if any. The Company's sole responsibility is to its Client and this document does not exonerate parties to a transaction from exercising all their rights and obligations under the transaction documents. Any unauthorized alteration, forgery or falsification of the content or appearance of this document is unlawful and offenders may be prosecuted to the fullest extent of the law.

Attention: To check the authenticity of testing inspection report & certificate, please contact us at telephone: (86-755) 8307 1443, or email: [CN.Doccheck@sgs.com](mailto:CN.Doccheck@sgs.com)

## Section 2: Photos of Company

### 2.1 Photos of Company and Product Sample

Description: Company Gate



Description: Factory Area



Description: Factory Area



Description: Office Building



Description: Office Hall



Description: Showroom



Unless otherwise agreed in writing, this document is issued by the Company under its General Conditions of Service accessible at <http://www.sgs.com/en/Terms-and-Conditions.aspx>. Attention is drawn to the limitation of liability, indemnification and jurisdiction issues defined therein. Any holder of this document is advised that information contained hereon is solely limited to visual examination of the safely and readily accessible portions of the consignment and reflects the Company's findings at the time of its intervention only and within the limits of Client's instructions, if any. The Company's sole responsibility is to its Client and this document does not exonerate parties to a transaction from exercising all their rights and obligations under the transaction documents. Any unauthorized alteration, forgery or falsification of the content or appearance of this document is unlawful and offenders may be prosecuted to the fullest extent of the law.

Attention: To check the authenticity of testing inspection report & certificate, please contact us at telephone: (86-755) 8307 1443, or email: [CN.Doccheck@sgs.com](mailto:CN.Doccheck@sgs.com)



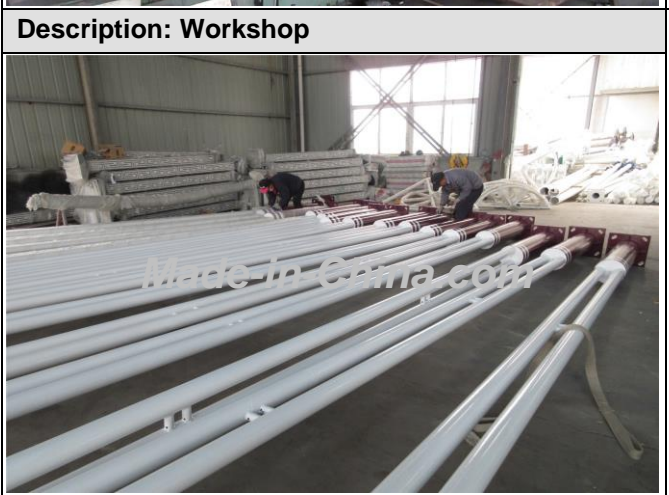

Unless otherwise agreed in writing, this document is issued by the Company under its General Conditions of Service accessible at <http://www.sgs.com/en/Terms-and-Conditions.aspx> Attention is drawn to the limitation of liability, indemnification and jurisdiction issues defined therein. Any holder of this document is advised that information contained hereon is solely limited to visual examination of the safely and readily accessible portions of the consignment and reflects the Company's findings at the time of its intervention only and within the limits of Client's instructions, if any. The Company's sole responsibility is to its Client and this document does not exonerate parties to a transaction from exercising all their rights and obligations under the transaction documents. Any unauthorized alteration, forgery or falsification of the content or appearance of this document is unlawful and offenders may be prosecuted to the fullest extent of the law.

Attention: To check the authenticity of testing inspection report & certificate, please contact us at telephone: (86-755) 8307 1443, or email: [CN.Doccheck@sgs.com](mailto:CN.Doccheck@sgs.com)

Page No.: 21 of 22

5F, B-4 Building, Zijin (Baixia) Technology Incubation Special Park, No.1 Guanghua Road, Nanjing, China 210014 t (86-25) 87128385 f (86-25) 83407773 www.sgsgroup.com.cn  
中国·南京·秦淮区光华路1号紫金白下创业特别社区4号楼B幢5楼 邮编: 210014 t (86-25) 87128385 f (86-25) 83407773 e as.cn@sgs.com





-- End of the Report --



Unless otherwise agreed in writing, this document is issued by the Company under its General Conditions of Service accessible at <http://www.sgs.com/en/Terms-and-Conditions.aspx> Attention is drawn to the limitation of liability, indemnification and jurisdiction issues defined therein. Any holder of this document is advised that information contained hereon is solely limited to visual examination of the safely and readily accessible portions of the consignment and reflects the Company's findings at the time of its intervention only and within the limits of Client's instructions, if any. The Company's sole responsibility is to its Client and this document does not exonerate parties to a transaction from exercising all their rights and obligations under the transaction documents. Any unauthorized alteration, forgery or falsification of the content or appearance of this document is unlawful and offenders may be prosecuted to the fullest extent of the law.

Attention: To check the authenticity of testing inspection report & certificate, please contact us at telephone: (86-755) 8307 1443, or email: [CN.Doccheck@sgs.com](mailto:CN.Doccheck@sgs.com)

Page No.: 22 of 22

SGS-CSI Standards Technical Services Co., Ltd.  
Consumer and Standards Technical Services

5F, B-4 Building, Zijin (Baixia) Technology Incubation Special Park, No.1 Guanghua Road, Nanjing, China 210014 t (86-25) 87128385 f (86-25) 83407773 www.sgs.com.cn  
中国·南京·秦淮区光华路1号紫金白下创业特别社区4号楼B幢5楼 邮编: 210014 t (86-25) 87128385 f (86-25) 83407773 e as.cn@sgs.com